

# Surface Mount Down Light Series

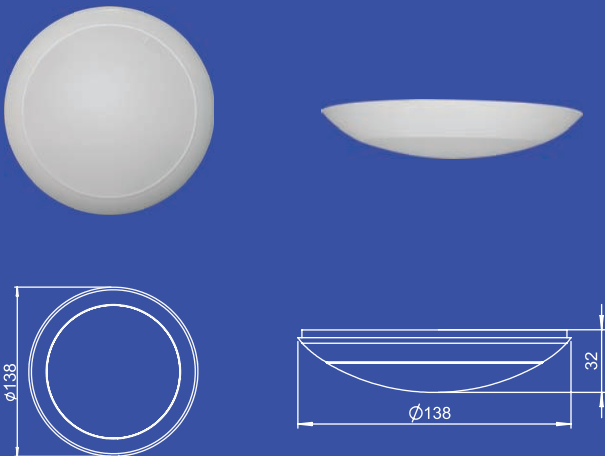

## Surface Down Light 5.5 Inch (10W)



## Surface Down Light 7.5 Inch (18W)

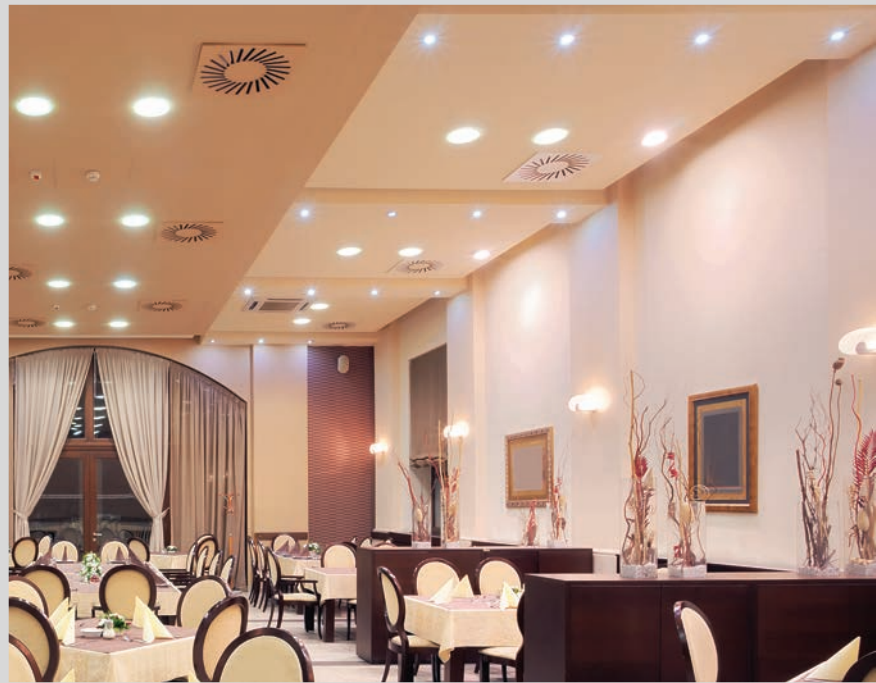
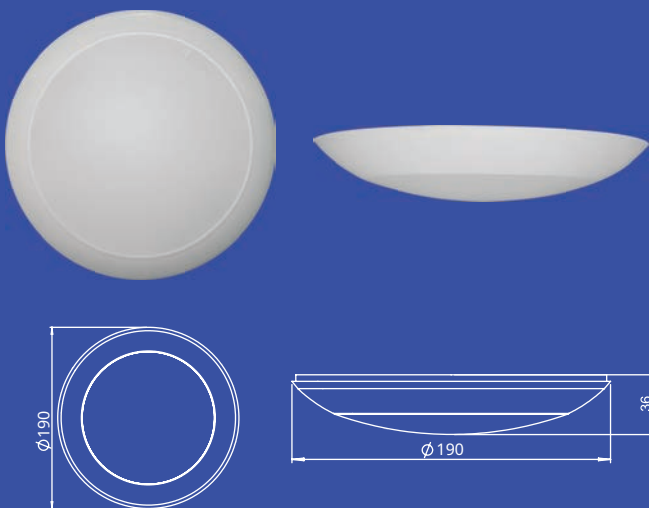

### Background:

The product was developed keeping in view the following important points:

- Basic fixtures like Junction-box-Lights rapidly catching the fancy of Indian consumer even in Tier II, Tier III Towns.
- Traditional Junction-box or down light require specific mounting requirement for installation.
- Large segment of typical Middle Class India do not have false ceiling to mount nice looking downlights
- Available basic surface-mount fixture designs are not attractive.
- There's a need for attractive, easy-install design with high visual appeal and aesthetics.

### Features:

- **Unique Looks and Stylish Design.**
- **Easily installed in all type of ceiling /surfaces**
- **Wide Beam for larger coverage & uniform lighting**
- **Surface Mount Simplicity, with Recessed Mount Looks**
- **Robust Technology meeting 440V/72 hour**

## Parts Details Of Disc Light

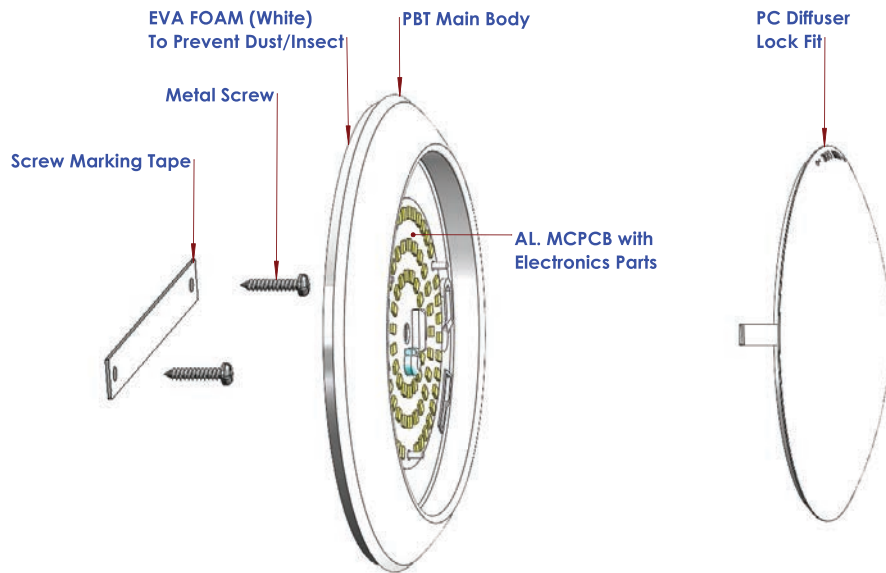

### Specification Table

Rated Wattage	10W / 5.5 Inch	18W / 7.5 Inch
Dimmable	No	No
Input Voltage	AC 120-300V, 50Hz	AC 120-300V, 50Hz
Power Factor	>0.90	>0.90
L70 Lifetime (Hrs.)	10,000	10,000
Input Current	40mA	75mA
CRI	80	80
CCT	6500K	6500K
LUMEN	800	1440
THD	≤ 30%	≤ 30%
Surge Protection	≥2.5KV	≥2.5KV
Weight (Kg)	0.08	0.11
Mounting Type	Surface Mount	
Limited Warranty	1 Year from the date of purchase	
Environment	IP22	
Cut-Out-(C-mm)	Not Required	
Height(H-mm)	32	36
Dia(D-mm)	138	190
Certified	LM80 Approved LED	

Click image for see Installation

